

# Design and Modeling of Trailer Battery Energy Storage for Range Extension of Electric Vehicles

Philippe Gommé<sup>1</sup> and Anthony M. Vassallo<sup>2</sup>

<sup>1</sup> School of Chemical & Biomolecular Engineering, University of Sydney, gomme.philippe@gmail.com

<sup>2</sup> School of Chemical & Biomolecular Engineering, University of Sydney, anthony.vassallo@sydney.edu.au

## Abstract

Automotive manufacturers have in the last few years put on the market new models of electric vehicles (EV) such as the Nissan Leaf and Tesla Roadster, demonstrating their awareness to the upcoming fossil/renewable energy transition. While the infrastructure around EVs is yet to be developed completely in most countries, potential buyers are being attracted by the idea of driving a vehicle which could save money by only using electricity as a source of energy. By extension, having a portable modular device in the form of a trailer attached to a vehicle and fitted with extra energy storage would allow current EVs to be used beyond their usual range limits, as well as provide space for carrying extra gear. This paper focuses on the electrical modeling and design of a battery pack fitted inside the trailer and a range estimation is calculated over a standardized driving cycle, using the high level programming language, Octave. A lithium based chemistry was chosen for numerical application, real data were used and case studies are presented to illustrate how the internal hardware of the trailer affects its performance. A value of 150 km of extra range was set as a target for the design, from which other trailer characteristics can be derived such as the weight distribution within the trailer and the maximum cornering speed. Overall, this work can be used as a preliminary design tool, able to accommodate different design options using the mathematical model employed.

## Keywords

trailer, battery pack, range, modelling, drive cycle

## 1. INTRODUCTION

Range anxiety in potential electric vehicle (EV) owners has previously been identified as a significant barrier to EV adoption [Nilsson, 2011]. This legitimate fear of “running out of fuel” does not seem to be allayed despite the fact that in Europe, more than 80 % of car journeys average below 20 km and Europeans drive less than 40 km per day [European Environment Agency, 2014]. Following from this observation, having an EV range extender in the form of a trailer may be sufficient to reassure people driving electric powered cars. Such a device would contain sufficient energy to drive an extra 150 km, as well as carry extra gear, for people wanting to drive their car for longer distances. Although this article sets the value of 150 km of extra range as a target, the study can easily be transferable to accommodate different designs targets, and different battery types.

## 2. DRIVE CYCLE

The modeling approach bases its calculation on the completion of the standardized driving cycle SPC 240 in use in Australia where SPC 240 stands for Short Petrol Composite Urban Emissions Drive Cycle 240

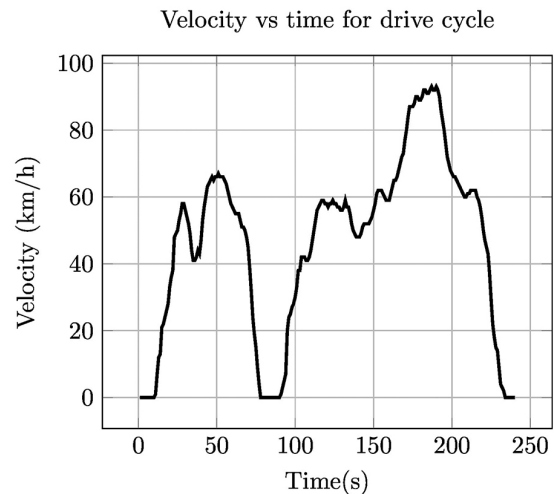

Fig. 1 SPC 240 drive cycle

seconds [Orbital Australia, 2005]. This cycle is simply what is to be considered a good representation of reality and is given on a strictly flat road with no hills. The velocity versus time profile for this cycle is shown in Figure 1. However, the analysis can be carried out for any driving cycle, assuming the data can be temporally discretized.

### 3. BATTERY MODELLING

#### 3.1 Cell level

In this paper, the mathematical modeling of the entire pack is based on the individual cell chemistry. Lithium based chemistry (Li-C/LiCoO<sub>2</sub>) [Boston Power, 2014] is considered a good candidate since it has been found to be well suited to electric vehicle applications [Linden, 2001]. Generally, any battery pack is the association of two or more cells, working together to deliver the power to the electric motor under the control of a Battery Management System (BMS). The open circuit voltage (Eoc) of a single cell under discharge at nominal capacity is given in Figure 2. It can be seen that the range for the open circuit voltage is relatively narrow across the whole depth of discharge (DoD) range typical of current cell performance.

The relationship that exists between the two variables, Eoc and DoD, can be approximated by a polynomial

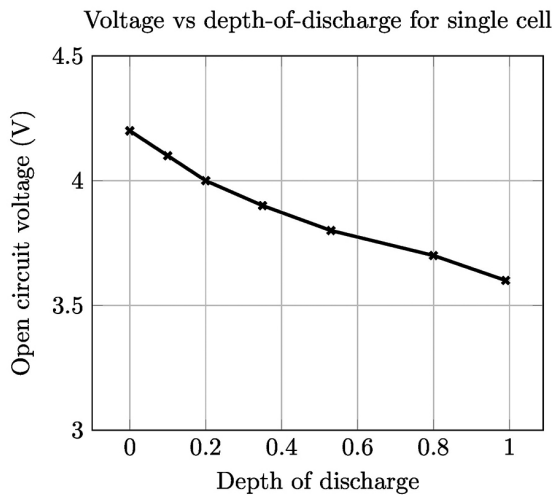

Fig. 2 Single lithium cell voltage at constant 1C discharge at nominal capacity

of degree 7 (equation 1) which is needed for modeling the entire battery pack:

$$E_{oc} = N_{Cells} * (-17.9 * DoD^7 + 28.4 * DoD^6 + 7.42 * DoD^5 - 35.7 * DoD^4 + 22.2 * DoD^3 - 4.3 * DoD^2 - 0.75 * DoD + 4.2) \quad (1)$$

The polynomial approximation of degree 7 has been found to be a good fit with the real data provided by the manufacturer of the battery cell. A first order approximation would still be possible but would carry across an error in the final results.

#### 3.2 Pack level

For electric vehicle applications, the battery pack can be sized according to its targeted range value. In our case, the need for an extra 150 km of extra range leads to choosing a battery pack containing approximately 30 kWh of electric energy. This 30 kWh figure was obtained by running the model over the SPC240 cycle successively until the extra range of 150 km is achieved and the energy requirement for the given range is found. Furthermore, depending on which driving cycle is used in the model, the resulting range may increase or decrease. However, the essential information that should be drawn from this energy figure is the number of cells required inside the pack to achieve the target range. These cells need to be arranged in a particular fashion to allow the overall Eoc and current outputs to match a given inverter, should an AC induction electric engine be used to convert DC into AC. A schematic of the pack layout is presented in Figure 3. The pack is made of individual cells that need to be arranged together, so that the Eoc voltage can fit a particular motor or inverter electrical characteristics as well as contain the required energy for

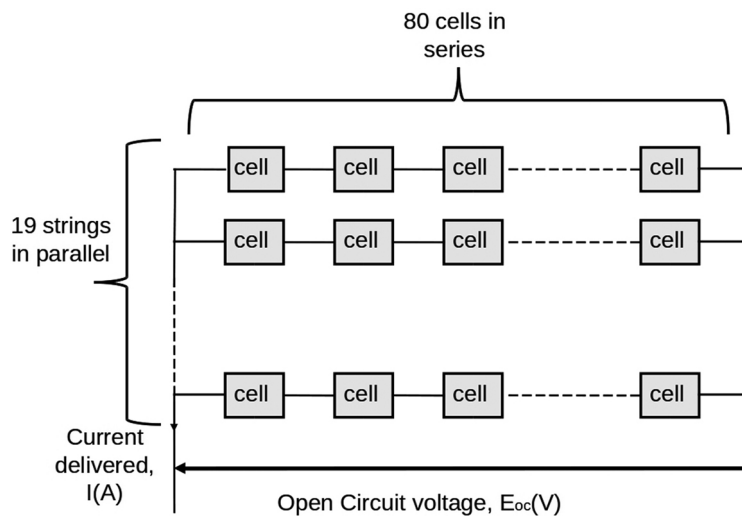

Fig. 3 Schematic of the battery pack layout

our automotive application. This leads to having 80 cells (each with stored energy of 19.3 Wh) in series per string, providing a pack voltage of 292 VDC, and 19 strings in parallel providing 30 kWh. The internal resistance is also of importance since its value can change with aging and temperature. Minimizing its initial value can reduce the losses by heat and therefore improve the performance.

With the Boston Swing 5300 cell taken as an example, the total internal resistance of the battery pack is calculated to be 0.114 Ohms using simple electrical circuit theory. Similarly, the total weight of the pack can be estimated by assuming that the BMS as well as the wiring and packaging add an extra 18 kilos, and that the 1520 individual cells themselves weigh about 142 kg according to the manufacturer, bringing the total battery pack mass to 160 kg.

**4. RESULTS**

**4.1 Preliminary simulation: Wide Open Throttle (WOT) test**

A simple WOT model can be implemented using the basics laws of physics to translate the acceleration of the vehicle and trailer in terms of differential equations. In automotive engineering, the sum of all resistive forces must be overcome in order for the vehicle to accelerate, that is:

$$F_{te} = F_{rr} + F_{ad} + F_{hc} + F_{la} + F_{wa} \tag{2}$$

Where:

- $F_{te}$  is the total force to be overcome
- $F_{rr}$  is the rolling resistance force
- $F_{ad}$  is the aerodynamic drag force
- $F_{hc}$  is the hill climbing force (set to zero here)
- $F_{la}$  is the force required to give linear acceleration
- $F_{oa}$  is the force required to give angular acceleration to the rotating motor

Figure 4 was obtained by substituting each term of equation 2 with its physical expression where in some term the acceleration of the vehicle,  $a$ , appears and can

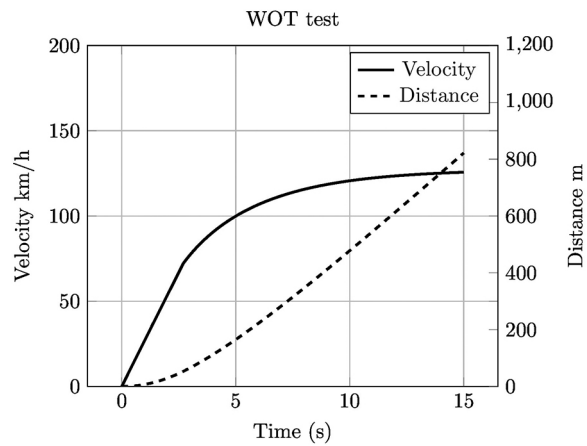

**Fig. 4** WOT test of a fully loaded electric car and trailer

be rewritten as  $dv/dt$ , the first derivative of the velocity with regards to time. By taking a time step equal to one second and knowing all the constants for the system, this equation becomes solvable and the velocity and distance traveled can be plotted against time.

The technology chosen for the modeling is an induction engine that can be described as having two modes of operation; either a constant torque or constant power mode. This observation is also valid for all motor types [Larminie and Lowry, 2003]. These electric motors are one of the most mature drive-train technologies, are low maintenance and relatively cheap [Larminie and Lowry, 2003] despite the need for an inverter to convert AC into DC electricity. As in any mathematical model involving acceleration of an object, mass does come into play and is here set to 1840 kg corresponding to a loaded car plus two passengers (1540 kg) as well as the loaded trailer (300 kg). Again, these figures are close estimates of reality and can be easily changed in the model to accommodate different scenarios. The results of the WOT model are shown in Figure 4.

While such a test is likely to drain the battery trailer quickly, it gives an indication of the vehicle ability to safely tow a trailer, as well as its ability to enter into traffic. Table 1 shows some performance figures for

**Table 1** Comparative performance of other main stream models from Tesla and Nissan [Tesla, 2014; Nissan, 2014]

Performance	Nissan Leaf	Tesla Roadster
Torque engine (N.m)	254	400
Power engine (kW)	80	215
Standing start 0 to 100 km/h (s)	10	3.7
Mass (kg)	1500	1230
Range (km)	175	393

commercially available electric vehicles for comparison.

### 5. RANGE MODELING

Once the battery pack is defined and modeled using equation 2, a range modeling simulation can be implemented to determine the maximum achievable range, provided solely by the trailer’s battery pack. In this section both the towing car and the trailer are loaded with some gear as well as two passengers. The Octave code used for this range modeling will start from a fully charged battery, and perform as many cycles as required to discharge the battery until 10 % of its energy is left, that is to say the Depth-of-discharge (DoD) is equal to 0.9. This approach involves the use of arrays to store the variables after each cycle completion including the DoD, electric charge removed and distance traveled. An overview of the results are presented in Figures 5 and 6. In Figure 6, two noticeable peaks (labeled as regenerative braking in the Figure) appear at specific times of the driving cycle where the

car is decelerating significantly. During these events, vehicle and trailer kinetic energy is recovered using the motor-generator. However, the driving cycle features more than two decelerations but they are not all as significant in terms of energy recovery. As well as the computation of electrical variables, other quantities can be plotted such as the resistive power imposed by the driving cycle and the electrical power required from the battery to overcome these resistive forces. As seen in Figure 5, the resistive power can become negative in sections of the cycle where the car is decelerating. In these cases, regenerative braking is applied and energy is recovered partially and fed back into the battery pack. When the car is at standstill, both the electric output from the battery and the resistive forces upon the car are zero. The battery power never becomes negative as the simulation is given on a flat road. In the event of a down hill section, the battery would recover a small portion of energy, as the term  $F_{hc}$  from equation 2 would contribute positively.

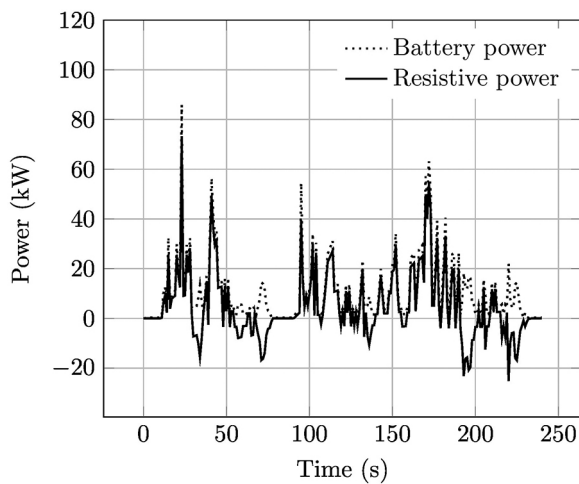

Fig. 5 Power flows during one SPC240 cycle

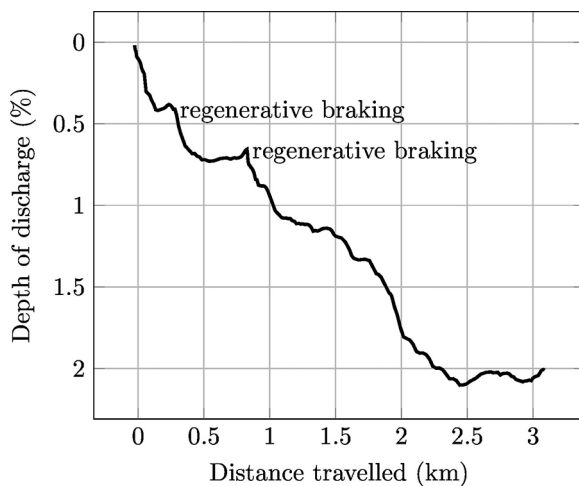

Fig. 6 Battery depth of discharge during first cycle

### 6. STABILITY OF TRAILERS

Trailers can be the cause of accidents especially when their load is inappropriately spread within their chassis. The risk of jackknifing could be higher when carrying large quantities of fluids (in the case of petrol tank carriers for instance) due to the fluid movement inside the tank or when the center of mass is located too high above the ground. In our case, the battery pack also needs to be located as close as possible to the tow bar to reduce any lateral instability. Although it is possible to limit such instabilities by applying asymmetric braking to the towing vehicle axle [Hac et al., 2009], the design of such a system was not considered here, rather the study of the coordinate position of the center of mass was addressed using a purely static analysis approach.

#### 6.1 Yaw axis stability

The longitudinal coordinate position of the center of mass  $G$  can be analyzed via the bicycle model theory where the equations of motion are based purely on geometric relationships governing the system [Rajamani, 2011]. A proposed model for finding the coordinate position of  $G$  in regards to the longitudinal axis is presented in Figure 7. It is important to note, however, that the following analysis cannot be used when dealing with dynamic effects, such as a time varying velocity and/or varying steering angle. The vector forces are shown here for representation only and are not to scale.

The symbols in Figure 7 are:

$F_y(\alpha)$  is the lateral force on the trailer tire

$F_{accl}$  is the lateral force exerted by the battery pack

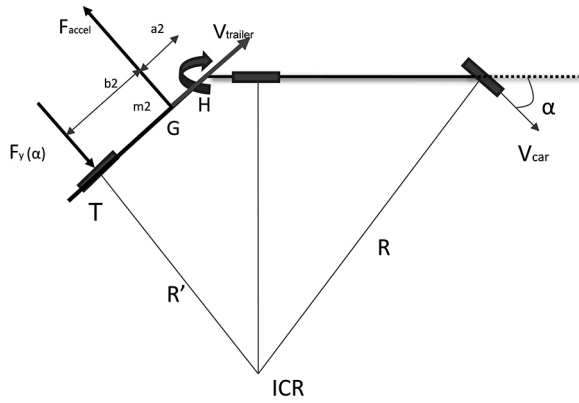

**Fig. 7** Simplified bicycle model of a trailer and its towing vehicle

on the trailer, equal to  $\frac{m_2 * V_{trailer}^2}{R'}$

$V_{trailer}$  is the trailer center of mass velocity

$V_{car}$  is the car cornering velocity

$b_2$  is the distance between the wheel centre and the centre of mass

$a_2$  is the distance between the center of mass and the hitch point

$R$  is the car constant cornering radius

$R'$  is the trailer constant cornering radius

ICR is the instant centre of rotation

$\alpha$  is the car steering angle

T,G and H are the tyre, center of mass and hitch point

$m_2$  is the mass of the battery pack

$F_y(\alpha)$  depends upon a number of parameters [Smith, 2004], including the friction coefficient  $\mu$  and the steering angle  $\alpha$  which are not discussed here. Assuming the towing vehicle is cornering at a constant velocity with a steering angle  $\alpha$ , the moment of rotation around the hitch point can be expressed as:

$$M_H = F(\alpha) * (a_2 + b_2) - F_{accel} * a_2 \quad (3)$$

where  $M_H$  is the moment of rotation around H.

It follows that if  $M_H \geq 0$ , the trailer's axle will remain stable; on the contrary, if  $M_H \leq 0$  the trailer may lose its grip and cause jackknifing. From a design perspective, the distance  $(a_2 + b_2)$  represents the wheelbase and is often set to a preliminary design target value, which implies that the unknown of equation (3) becomes  $V_{trailer}$ , the maximum allowable trailer cornering velocity. In a worse case scenario involving a low friction coefficient  $\mu$ , such as an icy road for example,  $M_H$  would become negative past a certain limit, leading to lateral instabilities. Equation 3 can be rewritten to express  $V_{trailerMaxJack}$  the maximum constant cornering velocity allowable by the trailer before initiating jackknifing. That is:

$$V_{trailerMaxJack} \leq \sqrt{\frac{F_y * R' * (a_2 + b_2)}{(a_2) * m_2}} \quad (4)$$

This formulation can be seen as an optimization problem where  $V_{trailerMaxJack}$  is the variable to maximize and  $F_y(\alpha)$ ,  $a_2$ ,  $b_2$  and  $R'$  are the variables to achieve this optimization.

A case study serves to illustrate the effect of these variables:

$F_y(\alpha) = 1300$  N (chosen as reasonable value),  $m_2 = 150$  kg, trailer cornering radius  $R' = 30$  m, HG distance  $a_2 = 0.7$  m, GT distance  $b_2 = 0.8$  m.

Note: the values of  $F_y(\alpha)$  and  $R'$  should be determined from a separate vehicle dynamics analysis to make sure that both variables are physically sound. It follows that the maximum cornering velocity to avoid jackknifing should be less than or equal to 23 m/s or 85 km/h.

### 6.2 Roll axis stability

The center of mass height at which a trailer is likely to roll over can be estimated by the Static Stability Factor (SSF). The SSF is used in the automotive industry for defining the lateral acceleration required for rollover in a rigid body model, and largely depends on the ratio of track width to the center of mass height [Roper, 2001]:

$$SSF = \frac{T}{2 * h} \quad (5)$$

where  $T$  is the track width and  $h$  is the height of the center of mass. Further to this, the critical velocity above which roll over may occur is given by:

$$V_{trailerMaxRoll} \leq \sqrt{(R' * SSF * g)} \quad (6)$$

It follows that in order for the trailer to stay stable, a compromise must be found between the track width and the height of the center of mass. Similar to the wheelbase, the track width can be seen as a preliminary design constraint, therefore can be set as a constant for the case study. The same cornering radius can be chosen from the yaw stability analysis in order to determine which of the two instabilities (jackknifing or rollover) happens first.

Case study:

$$SSF = 1.3. R' = 30m, g = 9.81 \text{ m/s}^2$$

It follows that  $V_{trailerMaxRoll}$  must be  $< 20$  m/s or 70 km/h in order for the trailer to avoid rollover.

## 7. SUMMARY OF THE STABILITY ANALYSIS

The cornering velocity is of primary importance in ensuring the stability of the trailer since its mathematical formulation is squared. The maximum lateral force that a tire can handle before losing its grip depends upon the friction coefficient, its vertical load or even its internal pressure. In the case study,  $F_y(\alpha)$  has been set to a realistic value for the purpose of this work.

The overall results of the case studies show that roll over happens before jackknifing according to theory and our case study, since  $V_{\text{trailerMaxJack}} > V_{\text{trailerMaxRoll}}$ . For both cases studied, arbitrary values were given for demonstration purposes to show how the equations can be used.

## 8. CONCLUSIONS

In this article a range simulation has been presented using the SPC240 driving cycle as an example. The results show that the extra mass induced by the trailer does not affect significantly the performance compared to having the same vehicle without trailer. It is mainly due to the fact that most electric engines have a high torque capability from low speeds. The steady state cornering stability of the trailer is also investigated via the use of kinematic relationships. The position of the centre of mass, and therefore the battery pack integration within the chassis, was described by equations 4 and 6. The simplified approach taken in this article has the main advantage of being adaptable to any design or conditions and could be particularly useful in helping choosing the right battery type and trailer dimensions to fit a particular towing vehicle.

## Acknowledgement

This work was also supported by the academic staff from the Ecole Supérieure des Techniques Aéronautiques et de Construction Automobiles (ESTACA, in Laval France), in particular Nassim Rizoug, from the embedded system department.

## References

- Boston Power, Swing 5300 rechargeable lithium-ion cell, 2014. URL <http://www.boston-power.com>. <http://www.boston-power.com>.
- European Environment Agency, The electric car -a green transport revolution in the making?, 2014. URL <http://www.eea.europa.eu/articles/the-electric-car-2014-a-green-transport-revolution-in-the-making>.
- Hac, A., D. Fulk, and H. Chen, Stability and control considerations of vehicle-trailer combinations, SAE Int. J. Passeng. Cars -Mech. Syst, 1:925-937, 2009. doi: doi:10.4271/2008-01-1228.
- Larminie, J and Lowry, J. , Electric vehicle technology

- explained. Wiley, West Sussex, first edition, 2003.
- Linden, D., *Handbook of Batteries*. McGraw-Hill Professional Publishing, 2001.
- Nilsson, M., Electric vehicles: The phenomenon of range anxiety. *Elvire Report*, 2011.
- Nissan, 2014. <http://www.nissan.fr>.
- Orbital Australia. Nise 2 - contract 2 drive cycle and short test development, Technical report, Orbital. Australia Pty Ltd for Department of the Environment and Heritage, 2005.
- Rajamani, R., *Vehicle dynamics and control*. Mechanical Engineering Series. 2nd edition, Springer, 2011.
- Roper, L. D., Physics of automobile rollovers. [https://www.accidentreconstruction.com/research/suv/rollovers\[1\].pdf](https://www.accidentreconstruction.com/research/suv/rollovers[1].pdf), 2001.
- Smith, N. D., Understanding parameters influencing tire modeling. Colorado State University, Formula SAE Platform, 2004. [http://www.engr.colostate.edu/pts/Job/Understanding\\_Parameters\\_Influencing\\_Tire\\_Modeling.pdf](http://www.engr.colostate.edu/pts/Job/Understanding_Parameters_Influencing_Tire_Modeling.pdf).
- Tesla motors, 2014. <http://www.teslamotors.com>.

(Received September 29, 2014; accepted November 8, 2014)